

DATA SHEET

***Stretch* DisplayPort™ DisplayPort 1.4 Extender with Copper Extension, DPFX-1F14-TR**

Contents

- **Description**
- **Features**
- **Applications**
- **Technical Specifications**
- **Recommended Operating Conditions**
- **DP Pin Description**
- **Dimensions**
- **Connection Diagram**

OPTICIS HQ

Opticis Co., Ltd.

3F, 305, Sanseong-daero, Sujeong-gu

Sungnam-si, Gyeonggi-do, 13354

South Korea

Tel: +82 (31) 719-8033

Fax: +82 (31) 719-8032

www.opticis.com

tosales@opticis.com

■ Description

DisplayPort 1.4 one(1) fiber optical extender with copper extension, DPFX-1F14, extends DisplayPort 1.4 signal up to 200m (656feet) and transmits 4K UHD (4096x2160) at 60Hz over one(1) LC multi-mode fiber. Cutting-edge technology of Opticis reduces limits in installation by providing an option for longer copper extension.

DPFX-1F14-TR transmit uncompressed and transparent data signal even when used with up to 3 m copper cable as an intermediary. This enables installation of the product in the limited spaced area in such our small module type extender cannot be used. 2m copper cable is provided in the shipping group.

Furthermore, to meet all the needs of the customers, DPFX-1F14-TR is fully interoperate with using DPFX-700-TR and DPFX-300-TR as a pair. Depending on the circumstances, customer can choose to use direct connection type module on one side, and copper extension type module on the other side.

DPFX-1F14-TR gives slim, light, and easy installation with perfect electrical isolation, but without electrical hazard and interference. It is operated external DC power adapter which is supplied in the shipping group.

The shipping items are shown as follows;

- 1) One (1) Transmitter (Tx) and One (1) Receiver (Rx)
- 2) Two (2) 2m Male to Male DisplayPort copper cable
- 3) Two (2) 5V 1A power adapter
- 4) User Manual

※ If the purchase was made with mixed pair of DPFX-700-TR and DPFX-300-TR, the shipping group may vary.

※ In shipping group, two 2m copper cables are included. Contact the regional sales representative or tosales@opticis.com for using 3m copper cable.

■ Features

- Compliance with DisplayPort standard: DisplayPort 1.4
- Extends up to 8K DSC(7680x4320) at 60Hz,
 - WHUXGA(7680x4320) at 60Hz 8K with DSC
 - WJXGA(5120x2880) at 60Hz 5K
 - WQUXGA(3840x2160) at 144Hz 4K
- Transmits DisplayPort1.4 data up to 200m(656feet) over one (1) LC multi-mode fiber (OM3)
- Extra Copper Extension available up to 3m on each side (TX/RX).
- Offers total data rate 32.4Gbps (8.1Gbps per lane).
- Fully interoperate with direct connection type module, DPFX-700-TR, DPFX-300-TR(It supports up to DisplayPort1.2).
- Firmware upgradable via micro USB port
- Support Multi-Stream Transport.
- Plug & Play
- Data security with negligible EMI emission
- Label color distinction: TX (purple) & RX (red purple)
- Certifies FCC and CE standards for EMI/RFI emission

■ Applications

- Medical imaging
- Military
- Digital Signage
- Control room
- Simulator
- Rental Staging

■ Technical Specifications

	Parameter	Specifications
Components	Laser Diodes in TX Module	Multi-mode VCSEL (Vertical Cavity Surface Emitting Laser)
	Photo Diodes in Rx Module	PIN-PD
Electrical	Input and Output Signals	ANSI 8B/10 Level (complying with DP1.2)
	Data Transfer Rate (Graphic Data)	Max. 5.4Gbps
	Total Jitter at the end of Rx output	Max. 0.5UI
Optical	Link Power Budget	Min. 1dB
Mechanical	Module dimension (LWH)	39 x 76 x 20mm
Connect	Optical Connector	Simplex LC connector
	Electric Connector Type from Systems and to Displays	20pin DP Receptacle Connector
	Recommended Fiber	OM3(50/125 um) Multi-mode Glass Fiber

■ Absolute Maximum Ratings

Stresses in excess of the absolute maximum ratings can cause permanent damage to the device. These are absolute stress ratings only. Functional operation of the device is not implied at these of any other conditions in excess of those given in the operational sections of the datasheet. Exposure to absolute maximum ratings for extended periods can adversely affect device reliability.

Parameter	Symbol	Min	Max	Unit
Supply Adapter Voltage	V _{CC}	-	6.0	V
Operating Temperature	T _{OP}	0	50	°C
Operating Relative Humidity	RH _{OP}	10	85 ¹⁾	%RH
Storage Temperature	T _{stg}	-30	70	°C
Storage Relative Humidity	RH _{stg}	10	95 ²⁾	%RH

Note

1), 2) Under the conditions of No drops of dew

■ Operating Conditions

■ Transmitter module: DPFX-1F14-T

	Parameter	Symbol	Minimum	Typical	Maximum	Units
Power Supply	Supply Voltage	V _{CC}	4.5	5.0	5.5	V
	Supply Current	I _{TCC}	435	440	445	mA
	Power Dissipation	P _{TX}	2.175	2.2	2.225	W
	Power Supply Rejection (Note1)	PSR		50		mV _{p-p}
DATA ANSI 8b/10b	Data Output Load	R _{LD}		50		Ω
	Transmitter Differential Input Voltage Swing (Peak-to-Peak)	V _{ID}	0.4	1.6	V _{ID}	V
Optical Link (Note3)	Output Optical Power	P _o			3	dBm
	Wavelength	λ	780		990	nm
	Spectral width in RMS	Δλ			3	nm
	Relative Intensity of Noise (Note2)	RIN		-20		dB/Hz
	Extinction Ratio	Ext	4			dB
	Rising/Falling Time	T _{rise} /T _{fall}			100	ps
	Jitter in p-p value (Note3)	T _{jitter}			90	ps

Note1. Tested with a 50mV_{p-p} sinusoidal signal in the frequency range from 500 Hz to 500 MHz on the V_{CC} supply with the recommended power supply filter in place. Typically less than a 0.25 dB change in sensitivity is experienced.

Note2. Measure in 1GHz of frequency bandwidth

Note3. Use PPG (Pulse Pattern Generator) source with jitter 50ps

■ Receiver module: DPFX-1F14-R

	Parameter	Symbol	Minimum	Typical	Maximum	Units
Power Supply	Supply Voltage	V _{CC}	4.5	5.0	5.5	V
	Supply Current	I _{RCC}	435	440	445	mA
	Power Dissipation	P _{RX}	2.15	2.175	2.2	W
	Power Supply Rejection (Note4)	PSR		50		mV _{p-p}
DATA ANSI 8b/10b	Data Input Load	R _{LD}		50		Ω
	Receiver Data Output Voltage Swing (Peak-to-Peak)	V _{ODp-p}		800		mV _{p-p}
Optical Link	Receiving Optical Power	P _o	-1			dBm
	Receiving Wavelength	λ	780		990	nm
	Link Power Budget	P _{bgt}	1			dB
	Total Jitter (note 5)	T _{Rjitter}			0.5	UI

Note4. Tested with a 50mV_{p-p} sinusoidal signal in the frequency range from 500 Hz to 500 MHz on the V_{CC} supply with the recommended power supply filter in place. Typically less than a 0.25 dB change in sensitivity is experienced.

Note5. It is measured as total jitters including Tx and Rx modules under maximum extension, 200 meters with 5.4Gbps.

■ Recommended specifications of fiber-optic cable

Parameters	Conditions	Specifications
Fiber Type		50μm Multi-mode Graded Index Glass Fiber
Modal Bandwidth	λ = 850nm	Min. 500 MHz km
Fiber Cable Attenuation	λ = 850nm	Max. 2.5dB/km
Extension Distance		10 – 1650ft (500 meters)
No. of Ferrules	Simplex LC	1 ferrule
Insertion Attenuation		Max. 0.5dB
Total Optical Attenuation	In 656 ft (200 meter) extension	Max. 1dB

■ DisplayPort Pin Description
TX Module

Pin	Symbol	Mating Row Contact Location	Functional Description
1	ML_Lane3(n)	Top	DisplayPort Data Lane3 Negative
2	GND	Bottom	Ground
3	ML_Lane3(p)	Top	DisplayPort Data Lane3 Positive
4	ML_Lane2(n)	Bottom	DisplayPort Data Lane2 Negative
5	GND	Top	Ground
6	ML_Lane2(p)	Bottom	DisplayPort Data Lane2 Positive
7	ML_Lane1(n)	Top	DisplayPort Data Lane1 Negative
8	GND	Bottom	Ground
9	ML_Lane1(p)	Top	DisplayPort Data Lane1 Positive
10	ML_Lane0(n)	Bottom	DisplayPort Data Lane0 Negative
11	GND	Top	Ground
12	ML_Lane0(p)	Bottom	DisplayPort Data Lane0 Positive
13	CONFIG1	Top	Cable Adaptor Detect
14	CONFIG2	Bottom	None
15	AUX CH(p)	Top	DisplayPort Aux Channel Positive
16	GND	Bottom	Ground
17	AUX CH(n)	Top	DisplayPort Aux Channel Negative
18	Hot Plug Detect	Bottom	HPD is used to detect a sink device by the source device
19	Return	Top	None
20	DP_PWR	Bottom	None

RX Module

Pin	Symbol	Mating Row Contact Location	Functional Description
1	ML_Lane0(p)	Top	DisplayPort Data Lane0 Positive
2	GND	Bottom	Ground
3	ML_Lane0(n)	Top	DisplayPort Data Lane0 Negative
4	ML_Lane1(p)	Bottom	DisplayPort Data Lane1 Positive
5	GND	Top	Ground
6	ML_Lane1(n)	Bottom	DisplayPort Data Lane1 Negative
7	ML_Lane2(p)	Top	DisplayPort Data Lane2 Positive
8	GND	Bottom	Ground
9	ML_Lane2(n)	Top	DisplayPort Data Lane2 Negative
10	ML_Lane3(p)	Bottom	DisplayPort Data Lane3 Positive
11	GND	Top	Ground
12	ML_Lane3(n)	Bottom	DisplayPort Data Lane3 Negative
13	CONFIG1	Top	Cable Adaptor Detect
14	CONFIG2	Bottom	None
15	AUX CH(p)	Top	DisplayPort Aux Channel Positive
16	GND	Bottom	Ground
17	AUX CH(n)	Top	DisplayPort Aux Channel Negative
18	Hot Plug Detect	Bottom	HPD is used to detect a sink device by the source device
19	Return	Top	None
20	DP_PWR	Bottom	None

■ Dimensions

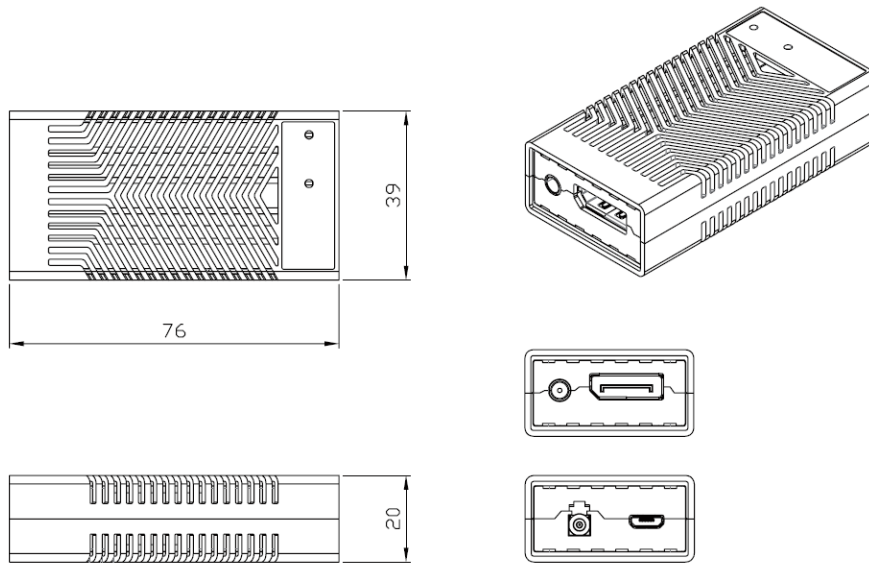

Dimensions (L*W*H): 39 x 76 x 20 mm

■ Connection Diagram

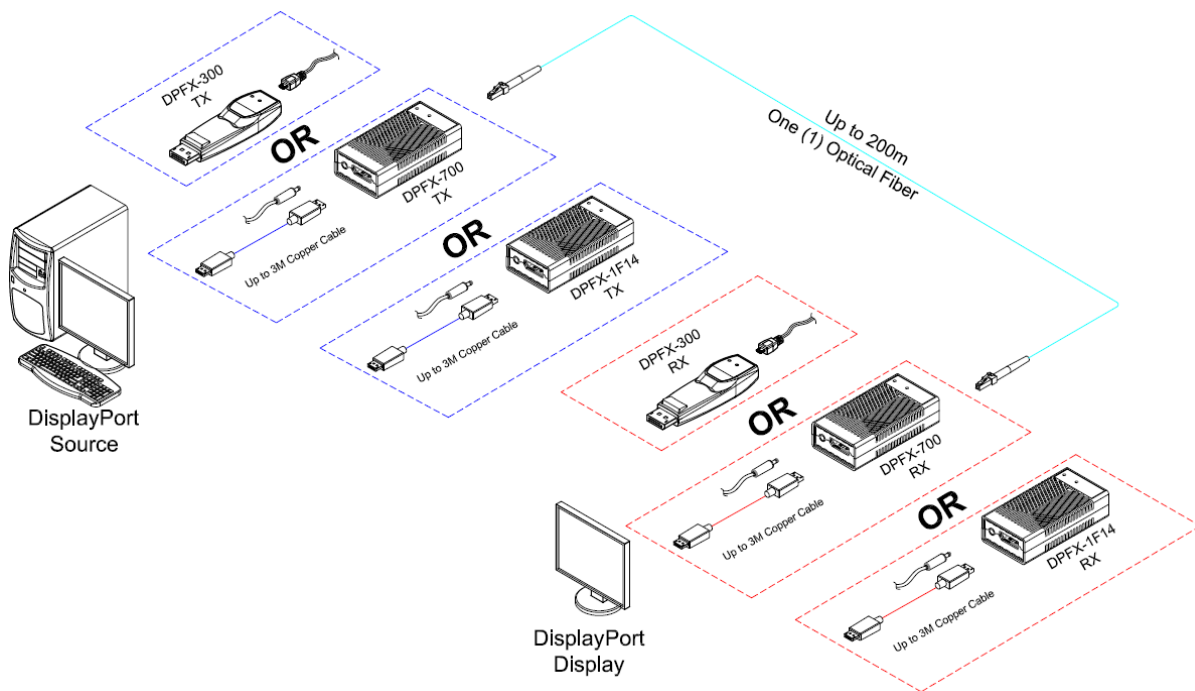



DPFX-1F14(v1.0)

Revision History

Version	date	History
0.9	2022-11	Preliminary version making
1.0	2023-01	Official marketing literature was released